

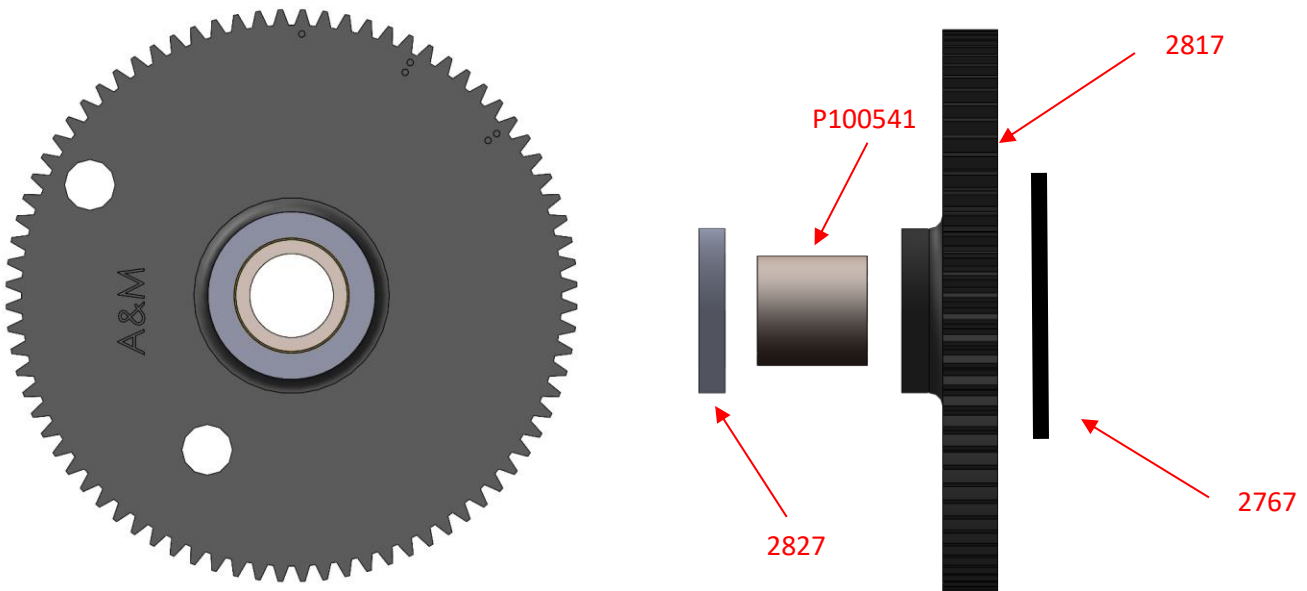

SERVING THE BUS TRANSPORTATION INDUSTRY
4121 Eastland Dr
Elkhart, IN 46516
Phone: 574-522-5000; FAX: 574-522-9099



K9158 – Gear, Universal Kit.
Replaces all gears featured on this document.



SERVING THE BUS TRANSPORTATION INDUSTRY
4121 Eastland Dr
Elkhart, IN 46516
Phone: 574-522-5000; FAX: 574-522-9099

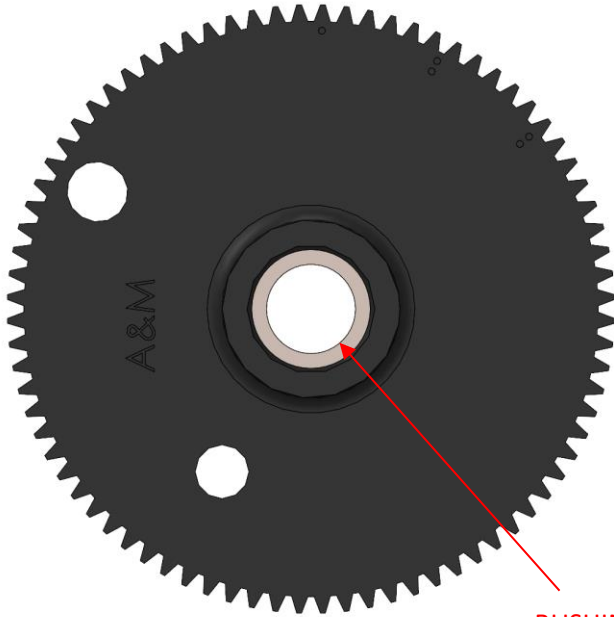

BUSHING 3/4" ID

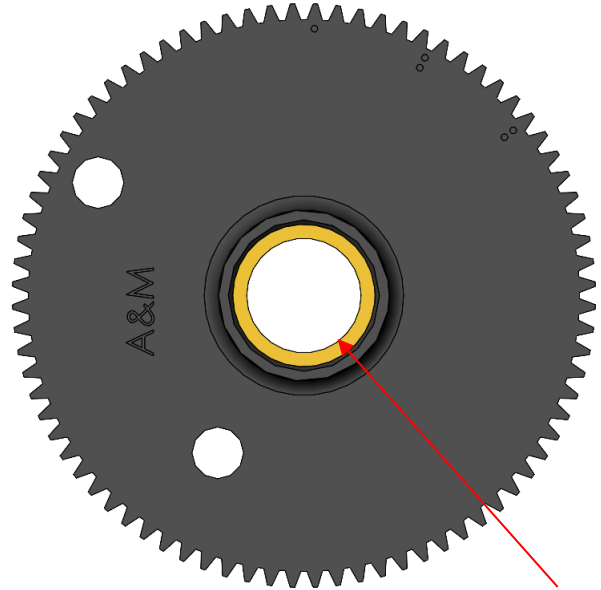

BUSHING 1" ID

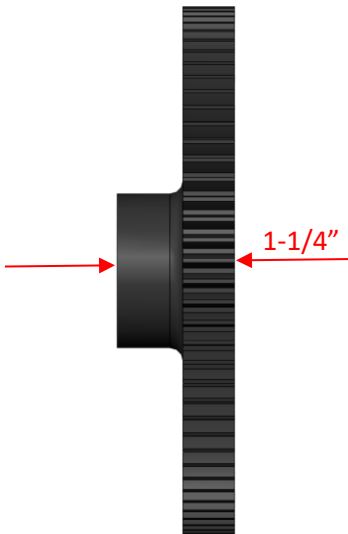

P100071 - 1-1/4" Tall Hub, 2 hole, 3/4" Gear Pin
For use with any dual gear horizontal or vertical actuator from 2000 through 2019. Additional 1/2" hole added in 2012. Model 3501 used through 2018. Discontinued. Can be replaced by K9158.

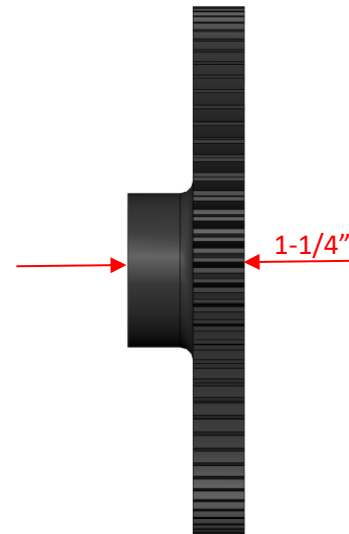

2154 - 1-1/4" Tall hub, 2 hole, 1" Gear Pin
For use with any model 4000, 3501 years 2109 - 2020. Began widespread use on horizontal and vertical dual gears headers in 2020. Discontinued. Can be replaced by 2817 and 2827 spacer.



SERVING THE BUS TRANSPORTATION INDUSTRY
4121 Eastland Dr
Elkhart, IN 46516
Phone: 574-522-5000; FAX: 574-522-9099

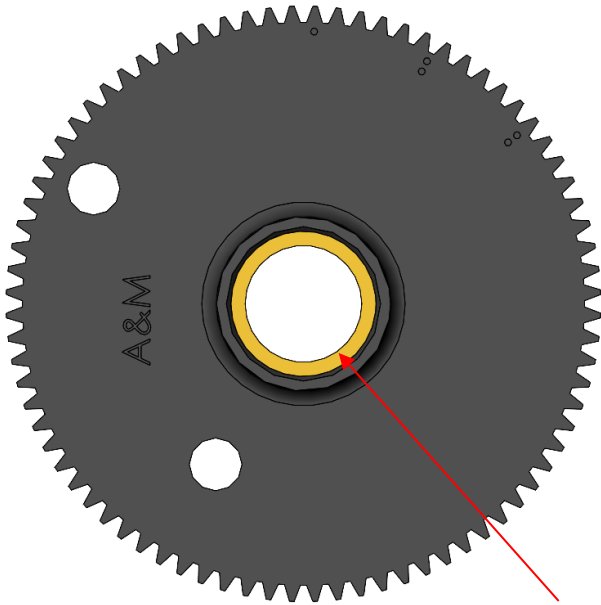

BUSHING 1" ID

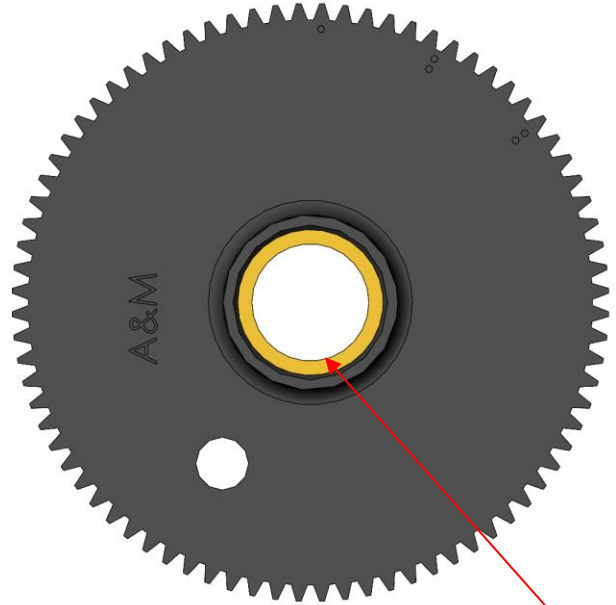
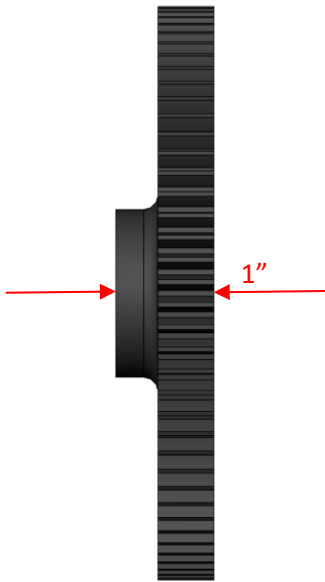

BUSHING 1" ID

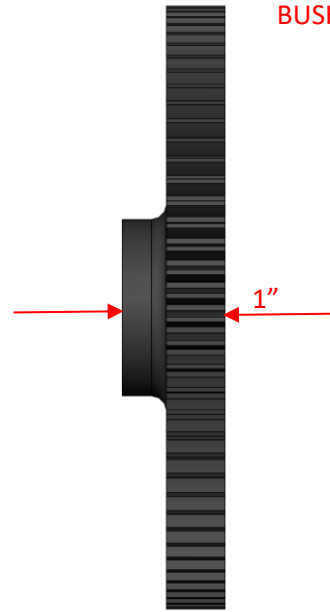

2817 – 1" Hub, 2 hole, 1" Gear Pin
For use on all headers beginning June 2020.

2873 – 1" Hub, 1 hole, 1" Gear Pin
Compatible with most horizontal and vertical dual gear
headers beginning June 2020
